

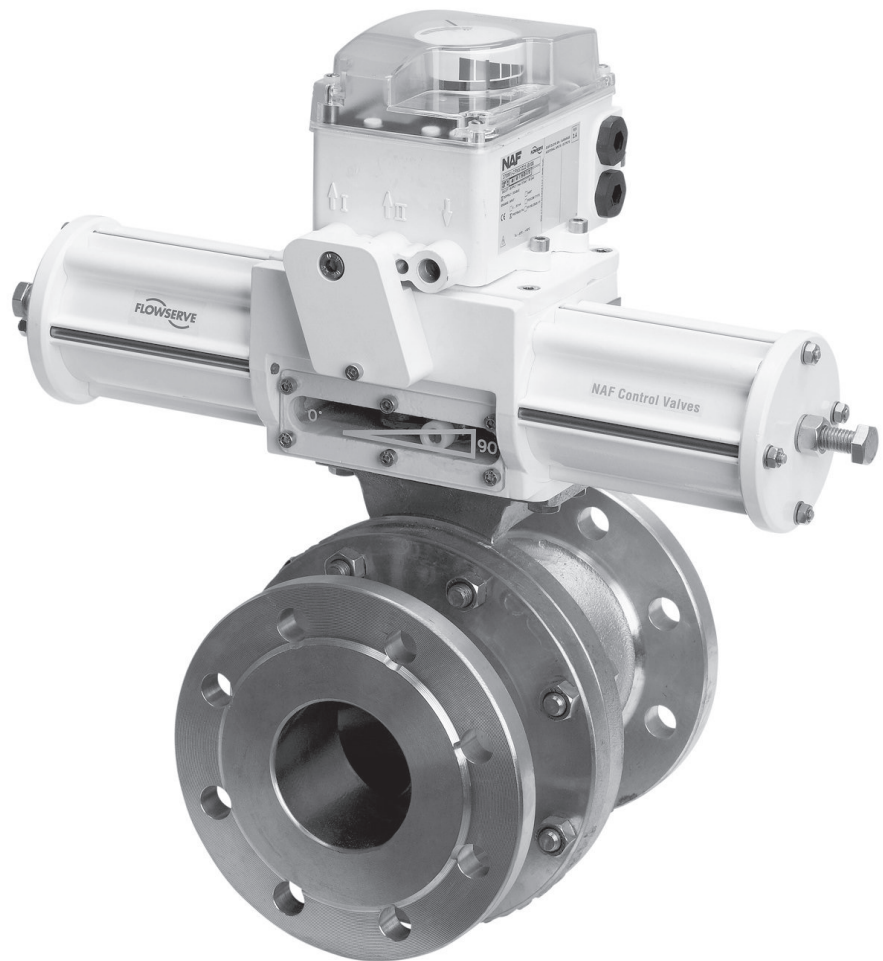

# *TECHNICAL BULLETIN*

## *NAF Trunnball DL Ball Valves*

FCD NFENTB4168-01-A4 12/14



## Primary Characteristics

The NAF Trunnball DL is a full-bore trunnion-mounted ball valve, developed by Flowserve engineers with more than 80 years of experience manufacturing ball valves. The ball is supported by two large, low friction trunnion bearings for consistent low torque even at high differential pressures. Due to its bidirectional tightness, low friction and high controllability, it is an excellent choice for isolation, on/off and modulating control applications.

NAF Trunnball DL is supplied as standard in stainless steel or carbon steel but is also available in other materials e.g. Duplex, titanium, etc.

The valve has:

- A **spring loaded stem seal packing** that provides long, maintenance-free and safe operation in automated on/off and control service
- **Direct actuator mounting** capabilities of the NAF Turnex actuator which provide a high performance, vibration resistant, compact valve package
- A sturdy, **blowout-proof stem** providing high torque transmission with a minimum mechanical backlash for **optimum controllability**
- A trunnion-mounted ball providing **bidirectional tightness**
- Low friction bearings for **low torque** and **smooth operation**
- The unique **Z-trim** option that **minimizes cavitation and noise** and has **excellent control characteristics**
- An **extensive size range**, DN 150–800, size 6” to 32”
- An **easy-to-service arrangement**, due to the off-center joint face of the valve body, which allows for easy replacement of the ball and seals without the need for removing the stem and actuator
- **Metal seats** with a rigid welded overlay of Alloy 6 or alternatively, **metal supported, reinforced PTFE seats**

**CE-marked** according to Pressure Equipment Directive (PED 97/23/EG) module H, category III. For module H1, category IV contact NAF.

## Technical specifications for standard design

<b>Material</b>	Stainless steel, carbon steel
<b>Size range</b>	DN 150-800, 6"-32"
<b>Pressure ratings</b>	PN 10-40, ANSI Class 150-300
<b>Face to Face lengths</b>	PN 10-16: EN558-1 series 12 PN 25-40: EN558-1 series 4 ANSI 150: ANSI B 16.10 Class 150 long ANSI 300: ANSI B 16.10 Class 300 short pattern, Size 6"-12"; Class 300 long pattern Size 14"-20"
<b>Valve Design</b>	ANSI B16.34 or EN 12 516
<b>Installation method</b>	Flanges to EN or ANSI B 16.5
<b>Temperature Range</b>	-30 - 250C, see graph on page 6 and 7
<b>Test procedure</b>	Body: 1.5 x maximum working pressure Seat: 1.1 x maximum allowed differential pressure Testing medium is water with inhibitor <sup>1</sup>
<b>Tightness class</b>	Soft seats EN 12266-1:2012, rate A (ISO 5208, rate A) Metal seats EN 60534-4 Class V ANSI FCI 70-2 Class V

<sup>1</sup>Gas test upon request

## ***Applications***

The excellent characteristics of NAF Trunnball DL are particularly beneficial under the most challenging operating conditions in the process industry, where difficult media and demanding pressure conditions make severe demands on the design, materials and performance.

NAF Trunnball DL is recommended for applications in the following industries:

- **Chemical and Petrochemical**
- **Pulp and Paper**
- **Oil and Gas**
- **Power Stations**
- **Metals and Mining**
- **General Industries**

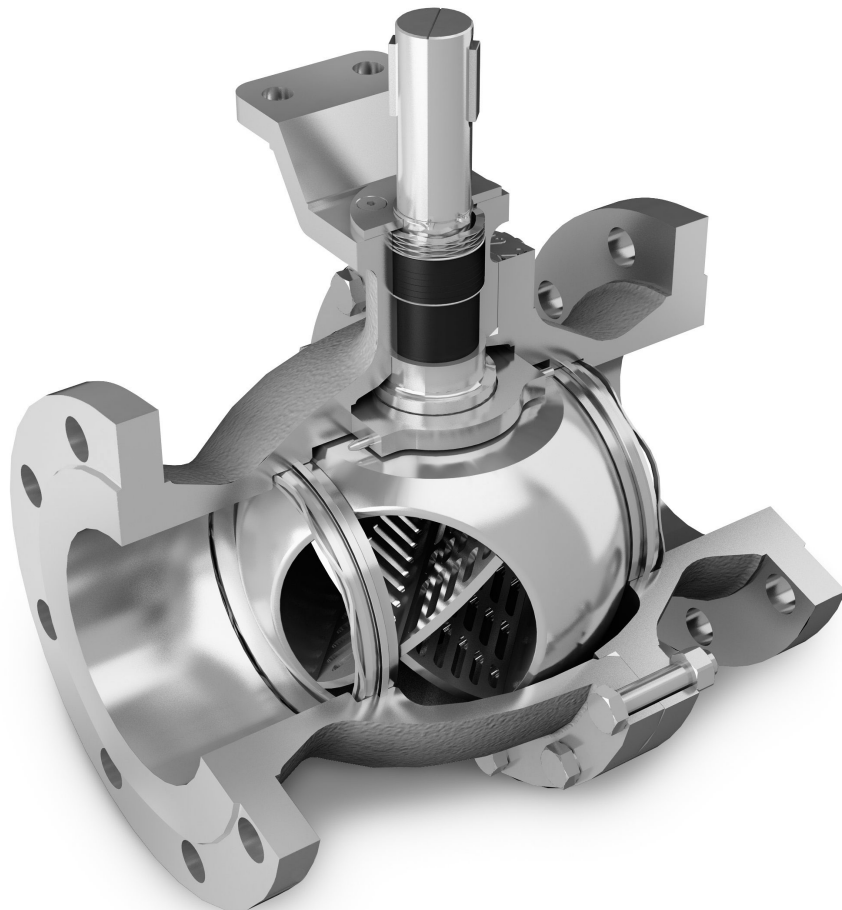

NAF Trunnball DL with optional Z-trim for noise attenuation and anti-cavitation use

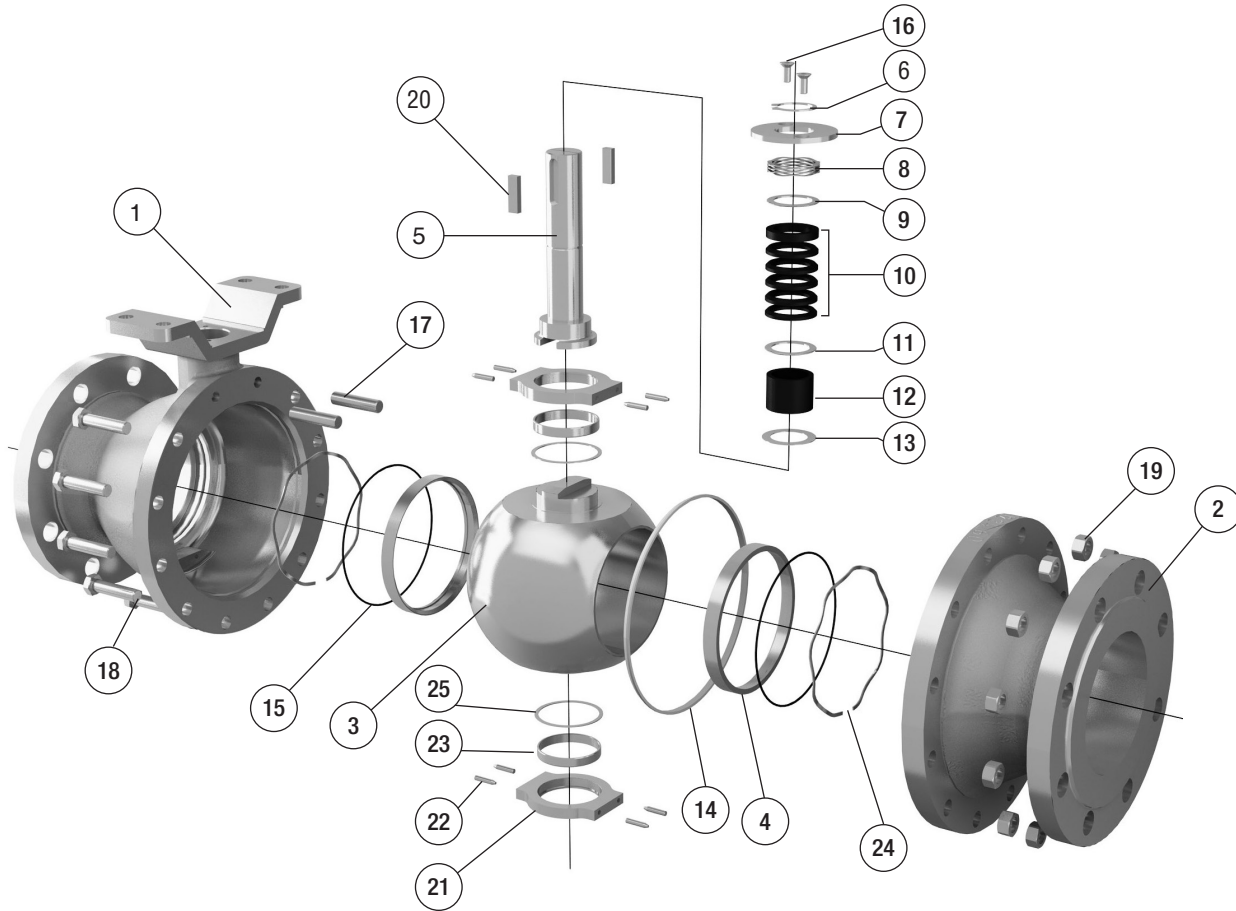

**Table 1: Materials (metal seated, standard version)**

Item	Qty	Part	Stainless steel	Carbon steel
1	1	Body, main	CF8M / 1.4408	WCB
2	1	Body, cover	CF8M / 1.4 408	WCB
3	1	Ball	CF8M / 1.4408 + Hard Chrome Plated	
4*	2	Seat ring	SS / Alloy 6	
5	1	Stem	EN 1.4460 (type AISI 329)	
6	1	Circlip	A2	
7	1	Cover	AISI 316L / EN 1.4404	
8	1	Spring	17-7PH	
9	1	Washer	AISI 316L / EN 1.4404	
10*	1	Stem packing	R-PTFE carbon reinforced	
11*	1	Washer	AISI 316L / EN 1.4404	
12*	1	Bushing	R-PTFE carbon reinforced	
13*	1	Anti-friction Washer	PTFE + stainless steel	
14*	1	Body seal	PTFE	
15*	2	Seat seal	PTFE	
16	**	Screw	A4	
17	2	Stud	A4/ASTM A193 gr. B8M	ASTM A193 gr. B7M
18	**	Bolt	A4/ASTM A193 gr. B8M	ASTM A193 gr. B7M
19	**	Nut	A4/ASTM A194 gr. 8M	ASTM A194 gr. 2HM
20	2	Key	A4	
21	2	Trunnion plate	EN 1.4470 (Duplex)	
22	8	Pin	AISI 316L/EN 1.4404	
23	2	Trunnion bearing	R-PTFE/SS	
24	2	Spring	AISI 316L/EN 1.4404	
25	2	Bearing washer	R-PTFE	

\* Recommended spare parts

\*\* Qty depends on the size

1.4408 = EN 10213-4 1.4408

CF8M = ASTM A351 gr. CF8M

Material combinations other than those specified are available to order - consult your Flowserve NAF representative. WCB = ASTM A216 gr. WCB

## Seat Rings

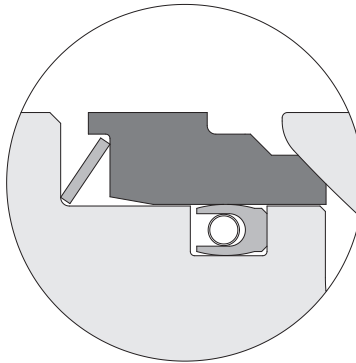

Metal seat standard

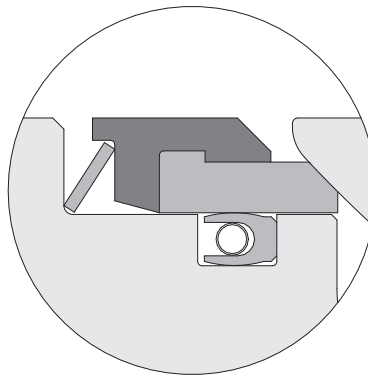

Soft seat standard

### Other versions

- **Degreased for oxygen service.** NAF Duball DL has an option D which needs to be specified for oxygen service. In this version all components are de-greased before assembly and a special grease, which is approved for oxygen service, is used in assembly.

Option: D

- **Explosive atmosphere** when intended for use in an explosive atmosphere, please specify option XA. With this option, the valve is certified according to ATEX 94/9/EC  $\text{Ex}$  II 2 G/D c.

Option: XA

- **Straight cylindrical flow path for sizes DN300-500/12"-20"**

For sizes DN300-500 / 12"-20" the balls are delivered as hollow balls in the standard version. Option C specifies a solid ball with a straight cylindrical flow path, normally used for applications such as blow-down and discharge valves.

Option: C

## Working Pressure and Temperature

### Max. working pressure PN rated valves

Stainless steel body (CF8M)

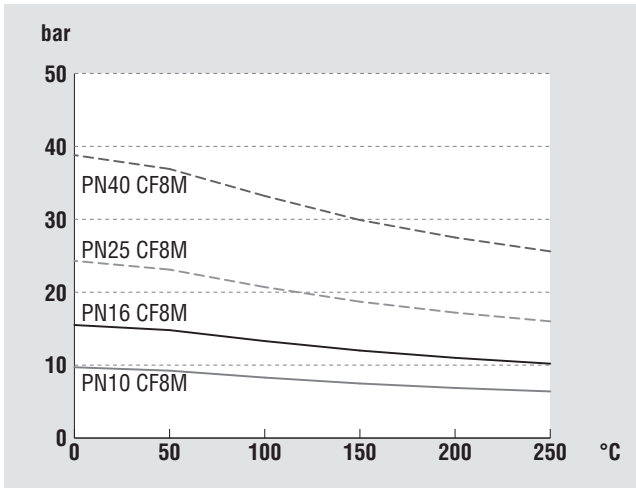

Carbon steel body (WCB)

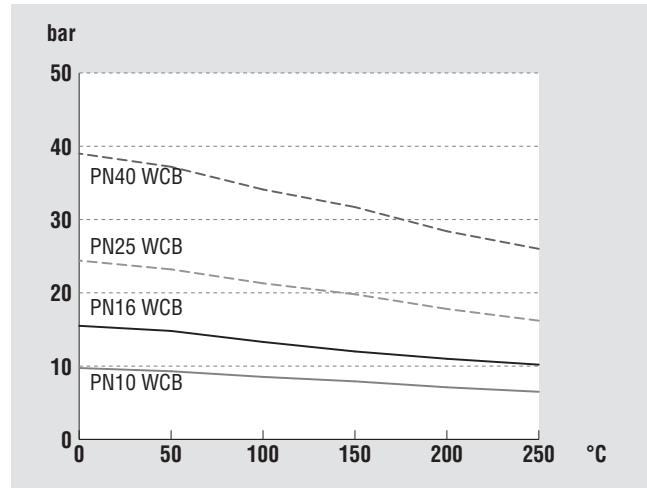

### Max. working pressure ANSI rated valves

Stainless steel body (CF8M)

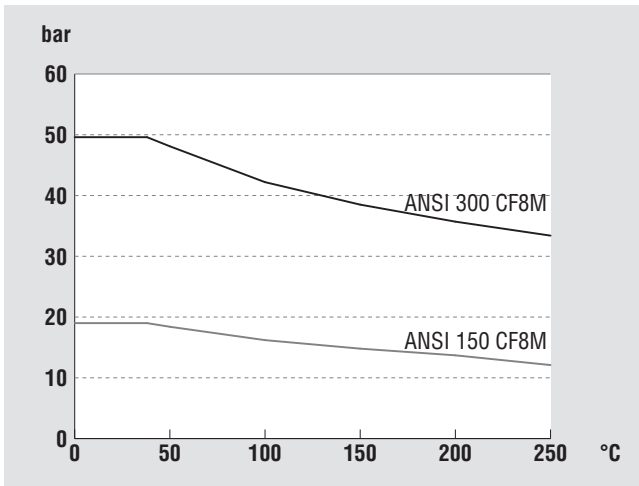

Carbon steel body (WCB)

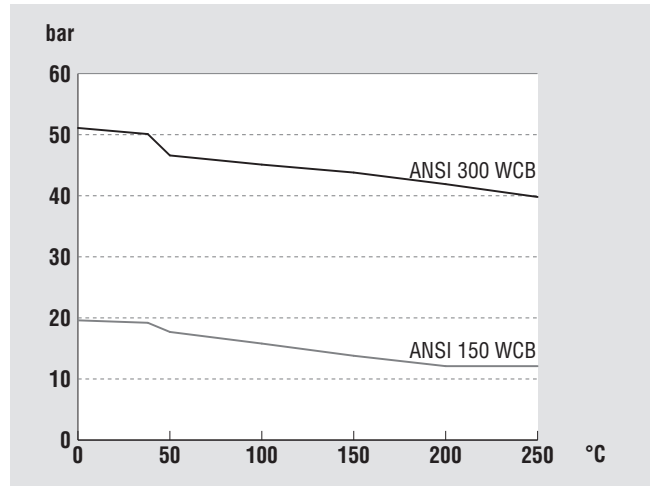

## Differential Pressure and Temperature

### Max. dp Alloy 6 seat

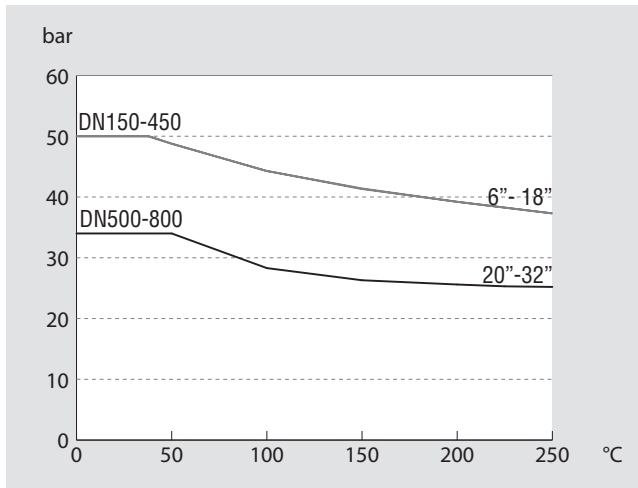

Please note that the maximum allowed differential pressure can be further reduced if the maximum allowed working pressure, based on body material and pressure class of the valve, is lower than the maximum allowed differential pressure.

### Max. dp R-PTFE seat

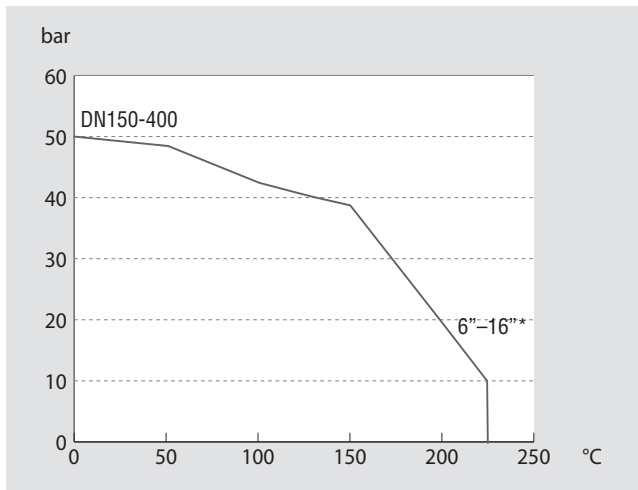

Soft R-PTFE seat ratings are based on differential pressure with the ball in the fully closed position and refer only to the seats. The maximum allowed differential pressure can be further reduced if the maximum allowed working pressure, based on body material and pressure class of the valve, is lower than the maximum allowed differential pressure.

\* For sizes bigger than DN400/16" please consult your Flowserve NAF representative

## Operating Torque and Flow Capacities

**Table 2: Operating torque, Nm**

DN	Size	Differential pressure in bar																	
		5		10		16		20		25		30		35		40		50	
		PTFE	Alloy 6	PTFE	Alloy 6	PTFE	Alloy 6	PTFE	Alloy 6	PTFE	Alloy 6	PTFE	Alloy 6	PTFE	Alloy 6	PTFE	Alloy 6	PTFE	Alloy 6
150	6	138	310	175	430	220	574	250	670	288	790	325	910	363	1030	400	1150	475	1390
200	8	360	650	480	910	624	1222	720	1430	840	1690	960	1950	1080	2210	1200	2470	1440	2990
250	10	565	1050	740	1480	950	1996	1090	2340	1265	2770	1440	3200	1615	3630	1790	4046	2140	4920
300	12	915	1525	1230	2150	1608	2900	1860	3400	2175	4025	2490	4650	2805	5275	3120	5900	3750	7150
350	14	1450	2435	1950	3320	2550	4382	2950	5090	3450	5975	3950	6860	4450	7745	4950	8630	5950	10400
400	16	2175	3475	2900	4850	3770	6500	4350	7600	5075	8975	5800	10350	6525	11725	7250	13100	8700	15850
450	18	*	4850	*	7200	*	10020	*	11900	*	14250	*	16600	*	18950	*	21300	*	2600
500	20	*	6400	*	9900	*	14100	*	16900	*	20400	*	23900	*	27400	*		*	
600	24	*	11100	*	16600	*	23200	*	27600	*	33100	*	38600	*	44100	*		*	
700	28	*	16500	*	24000	*	33000	*	39000	*	46500	*	54000	*	61500	*		*	
800	32	*	21500	*	32000	*	44600	*	53000	*	63500	*	74000	*	84500	*		*	

\* For torque values please contact your Flowserve NAF representative

The minimum design differential pressure for selecting the actuator is 5 bar.

The specified torques in the table above are for clean media. For steam and with Alloy 6 seat rings increase the required torque by a factor of 1.5.

If the media is a slurry or contains solids etc., consult NAF.

**Table 3: Flow capacities and characteristics**

DN	Size	C <sub>v</sub> at an opening angle of														C-option at 90° opening angle	Z-trim option at 90° opening angle
		15°	20°	25°	30°	35°	40°	45°	50°	55°	60°	65°	70°	80°	90°		
150	6"	23	39	63	90	134	182	238	310	348	526	694	933	1842	4517		1886
200	8"	14	44	84	134	197	270	368	476	628	832	1082	1461	3311	9198		3246
250	10"	70	121	196	277	351	517	676	879	1150	1486	1683	2569	5219	14028		6094
300	12"	31	132	245	417	552	714	934	1196	1504	1909	2491	3343	6700	12439	23333	8620
350	14"	120	229	455	536	758	951	1213	1513	1971	2445	3335	4202	7603	15158	30418	10633
400	16"	198	395	593	791	989	1277	1628	2027	2638	3341	4317	5641	10807	19774	41942	16315
450	18"	260	452	687	959	1269	1639	2075	2642	3407	4346	5457	7031	14408	26196	53457	18907
500	20"	300	600	901	1201	1501	1952	2401	3170	3902	5103	6440	8332	15800	30018	56536	25537
600	24"	366	732	1025	1542	1464	2829	3660	4814	5124	7970	9516	14107	29669	73200		
700	28"	513	1026	1437	1866	2053	3407	4618	6096	7184	10205	13341	17881	38440	102625		
800	32"	857	1713	2399	3427	4112	5253	6854	8924	11994	14837	22274	30841	52438	171339		

$$K_v = C_v / 1.16$$



## Dimensions and Weight

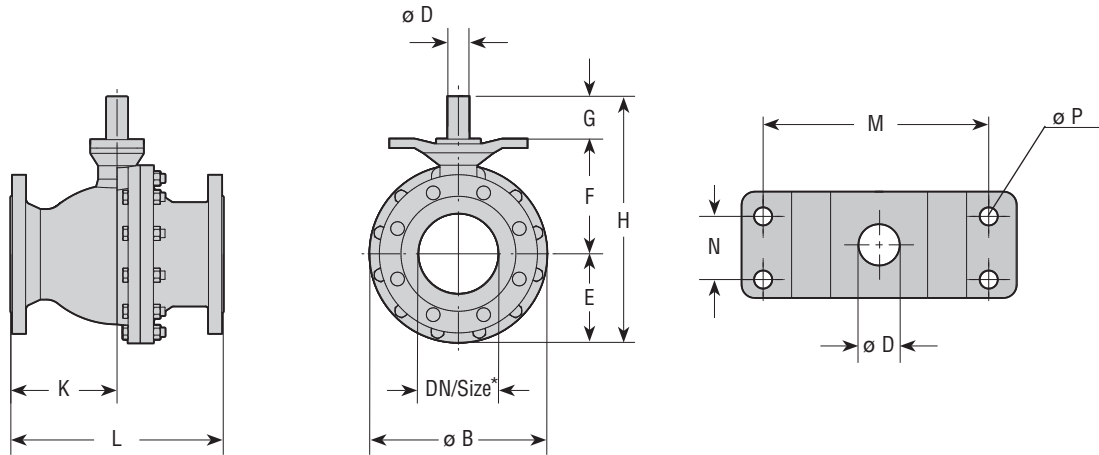

\* Indicates nominal valve size

**Table 4a: Valve dimensions and weight - PN10, PN16 and ANSI Class 150**

DN	Size	Dimensions, mm											Weight kg <sup>1</sup>
		B	D	E	F	G	H	K	L	M	N	P	
150	6"	336	40	168	249	80	497	197	394	214	60	18	100
200	8"	426	50	213	302	80	595	229	457	214	60	18	175
250	10"	528	50	264	356	93	713	267	533	214	60	18	269
300	12"	606	70	303	412	93	808	305	610	277	115	33	380
350	14"	688	80	344	506	149	999	343	686	277	115	33	546
400	16"	767	80	384	567	149	1100	381	762	277	115	33	701
450	18"	827	80	414	542	149	1105	432	864	277	115	33	910
500	20"	936	80	468	596	149	1213	457	914	277	115	33	1280
600	24"	1260	110	630	800	240	1670	534	1067	*	*	*	*
700	28"	1400	120	700	870	240	1810	622	1244	*	*	*	*
800	32"	1500	130	750	920	242	1912	686	1372	*	*	*	*

**Table 4b: Valve dimensions and weight - PN25, PN40 and ANSI Class 300**

DN	Size	Dimensions, mm											Weight kg <sup>1</sup>
		B	D	E	F	G	H	K	L	M	N	P	
150	6"	336	40	168	249	80	497	202	403	214	60	18	108
200	8"	452	50	226	302	93	621	210	419	214	60	18	203
250	10"	528	60	264	356	111	731	229	457	214	60	18	313
300	12"	622	70	311	412	131	854	251	502	277	115	33	424
350	14"	688	80	344	506	149	999	382	762	277	115	33	651
400	16"	767	100	384	567	190	1141	419	838	277	115	33	862
450	18"	827	100	414	542	190	1146	457	914	277	115	33	1079
500	20"	936	100	468	596	190	1254	496	991	277	115	33	1490
600	24"	1300	110	650	800	240	1690	571	1143	*	*	*	*
700	28"	1400	120	700	870	240	1810	622	1244	*	*	*	*
800	32"	1500	130	750	920	242	1912	686	1372	*	*	*	*

<sup>1</sup> Applies to average weight within the pressure classes in the tables

\* Contact Flowserve NAF representative

## Actuators

NAF Trunnball DL is available with worm gears, pneumatic actuators or with electrical actuators and accessories. If other pneumatic or electrical actuators are required, consult your Flowserve NAF representative.

The maximum differential pressure for selected actuator and valve is based on torque values in table 2 and is valid for clean media, e.g. water. For steam and other media, please see notes under table 2.

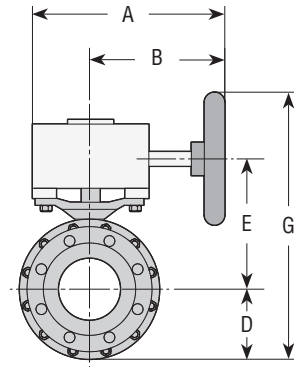

**Table 5a: NAF Trunnball DL valves with worm gears - PN10, PN16 and ANSI Class 150**

DN	Size	Max. dp bar Seat of		NAF No.	Dimensions, mm					Weight kg <sup>1</sup>
		R-PTFE	Alloy 6		A	B	D	E	G	
Worm gear actuator as per Fk 70.76 <sup>2</sup>										
150	6"	20	20	791051-33040	416	291	168	299	667	116
200	8"	20	20	791051-33050	416	291	213	352	765	191
250	10"	20	16	791051-33050	416	291	264	406	870	285
250	10"	20	20	791051-43050	507	337	264	421	935	301
300	12"	20	20	791051-55070	591	421	303	467	970	418
350	14"	20	20	791051-55080	591	421	344	561	1105	584
400	16"	20	16	791051-55080	591	421	384	622	1206	739
400	16"	20	20	791051-65080	697	487	384	656	1340	768
450	18"	*	20	791051-65080	697	487	414	631	1345	977
500	20"	*	18	791051-75080	747	537	468	720	1480	1361
500	20"	*	20	791051-85080	848	593	468	681	1499	1472
600	24"	*	*	*	*	*	*	*	*	*
700	28"	*	*	*	*	*	*	*	*	*
800	32"	*	*	*	*	*	*	*	*	*

<sup>1</sup> Applies to average weight within the pressure classes in the tables

<sup>2</sup> Available with locking device - please contact Flowserve NAF representative

\* For information, please contact Flowserve NAF representative

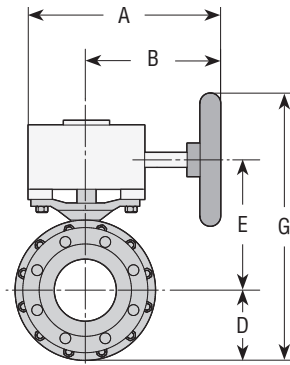

**Table 5b: NAF Trunnball DL valves with worm gears - PN25, PN40 and ANSI Class 300**

DN	Size	Max. dp bar Seat of		NAF No.	Dimensions, mm					Weight kg <sup>1</sup>
		R-PTFE	Alloy 6		A	B	D	E	G	
Worm gear actuator as per Fk 70.76 <sup>2</sup>										
150	6"	50	50	791051-33040	416	291	168	299	667	124
200	8"	50	30	791051-33050	416	291	213	352	778	219
200	8"	50	50	791051-43050	507	337	213	367	843	235
250	10"	48	16	791051-33060	416	291	264	406	870	329
250	10"	50	40	791051-43060	507	337	264	421	935	345
250	10"	50	50	791051-53060	591	421	264	411	875	351
300	12"	50	45	791051-55070	591	421	303	467	978	462
300	12"	50	50	791051-65070	697	487	303	501	1113	491
350	14"	50	28	791051-55080	591	421	344	561	1105	689
350	14"	50	50	791051-65080	697	487	344	595	1239	718
400	16"	35	16	791051-55100	591	421	384	622	1206	900
400	16"	50	35	791051-65100	697	487	384	656	1340	929
400	16"	50	50	791051-75100	747	537	384	691	1375	943
450	18"	*	20	791051-65100	697	487	414	631	1345	1146
450	18"	*	30	791051-75100	747	537	414	666	1380	1160
450	18"	*	50	791051-85100	848	593	414	627	1391	1271
500	20"	*	18	791051-75100	747	537	468	720	1488	1571
500	20"	*	20	791051-85100	848	593	468	681	1499	1682
600	24"	*	*	*	*	*	*	*	*	*
700	28"	*	*	*	*	*	*	*	*	*
800	32"	*	*	*	*	*	*	*	*	*

<sup>1</sup> Applies to average weight within the pressure classes in the tables

<sup>2</sup> Available with locking device- please contact Flowserve NAF representative

\* For information, please contact Flowserve NAF representative

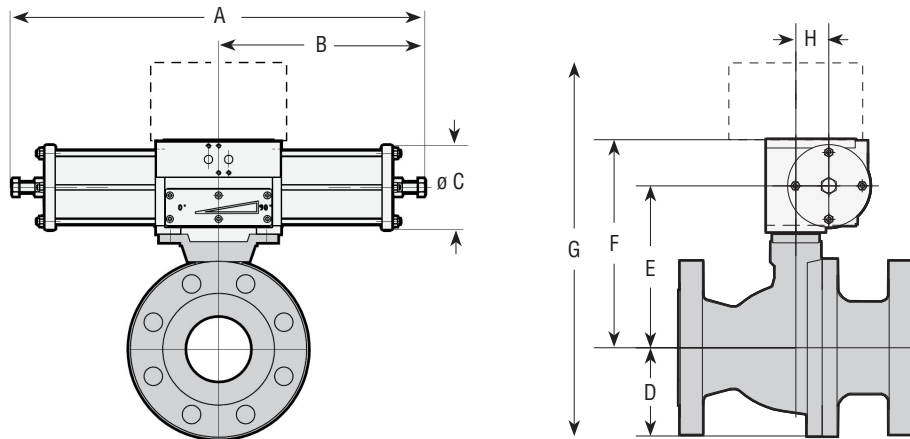

NAF 791290/791390

**Table 6a: NAF Trunnball DL valves with NAF Turnex pneumatic actuator (double acting) - PN10, PN16 and ANSI Class 150**

DN	Size	Max dP bar at supply of						NAF No.	Dimensions, mm								Weight kg <sup>1</sup>
		4 bar		5 bar		6 bar			A	B	C	D	E	F	G <sup>2</sup>	H	
		R-PTFE	Alloy 6	R-PTFE	Alloy 6	R-PTFE	Alloy 6										
150	6"	20	5	20	8	20	12	791290-2140	700	350	145	168	324	397	675	63	117
150	6"	20	18	20	20	20	20	791290-2240	700	350	145	168	324	397	675	63	117
150	6"	20	20	20	20	20	20	791290-3140	820	410	200	168	349	441	719	75	129
200	8"	20	11	20	16	20	20	791290-3150	820	410	200	213	402	494	817	75	204
200	8"	20	20	20	20	20	20	791290-3250	820	410	200	213	402	494	817	75	204
250	10"	16	-	20	7	20	9	791290-3150	820	410	200	264	456	548	922	75	298
250	10"	20	15	20	20	20	20	791290-3250	820	410	200	264	456	548	922	75	298
250	10"	20	20	20	20	20	20	791390-4250	1110	555	260	264	484	616	990	100	335
300	12"	20	20	20	20	20	20	791390-4270	1110	555	260	303	540	672	1085	100	446
350	14"	10	-	15	5	20	8	791390-4180	1110	555	260	344	634	766	1220	100	612
350	14"	20	14	20	20	20	20	791390-4280	1110	555	260	344	634	766	1220	100	612
350	14"	20	20	20	20	Max air supply 5 bar		791390-4580	1250	695	395	344	634	766	1220	100	656
400	16"	18	7	20	11	20	14	791390-4280	1110	555	260	384	695	827	1321	100	767
400	16"	20	19	20	20	Max air supply 5 bar		791390-4580	1250	695	395	384	695	827	1321	100	811
400	16"	20	20	20	20	20	20	791390-5180	1600	800	395	384	749	897	1391	150	921
450	18"	*	-	*	5	*	7	791390-4280	1110	555	260	414	706	811	1320	100	976
450	18"	*	10	*	14	Max air supply 5 bar		791390-4580	1250	695	395	414	706	811	1320	100	1020
450	18"	*	11	*	15	*	19	791390-5180	1600	800	395	414	724	872	1396	150	1130
450	18"	*	20	*	20	*	20	791390-5280	1600	800	395	414	724	872	1396	150	1130
500	20"	*	6	*	8	Max air supply 5 bar		791390-4580	1250	695	395	414	760	865	1428	100	1390
500	20"	*	7	*	9	*	12	791390-5180	1600	800	395	468	778	926	1504	150	1500
500	20"	*	18	*	20	*	20	791390-5280	1600	800	395	468	778	926	1504	150	1500
600	24"	*	*	*	*	*	*	*	*	*	*	*	*	*	*	*	*
700	28"	*	*	*	*	*	*	*	*	*	*	*	*	*	*	*	*
800	32"	*	*	*	*	*	*	*	*	*	*	*	*	*	*	*	*

<sup>1</sup> Applies to average weight within the pressure classes in the tables

<sup>2</sup> Including all direct mounted Flowserve positioners (NAF 37-series, NAF-LinkIT, PMV P5/EP5, PMV D3, PMV D20, Logix 520MD+)

\* Contact Flowserve NAF representative

The above stated dP apply for clean media type water 20°C.

For other media contact Flowserve NAF, see also page 8.

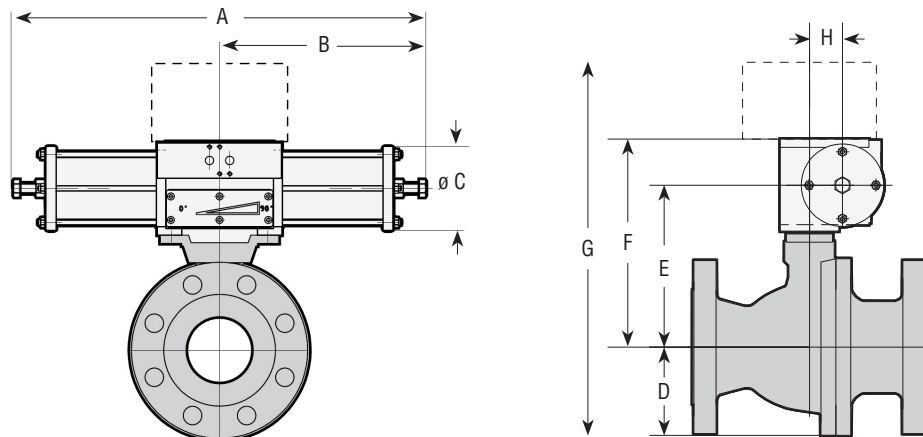

NAF 791290/791390

**Table 6b: NAF Trunnball DL valves with NAF Turnex pneumatic actuator (double acting)- PN25, PN40 and ANSI Class 300**

DN	Size	Max dP bar at supply of						NAF No.	Dimensions, mm								Weight kg <sup>1</sup>
		4 bar		5 bar		6 bar			A	B	C	D	E	F	G <sup>2</sup>	H	
		R-PTFE	Alloy 6	R-PTFE	Alloy 6	R-PTFE	Alloy 6										
150	6"	26	5	37	8	48	12	791290-2140	700	350	145	168	324	397	675	63	125
150	6"	50	18	50	25	50	31	791290-2240	700	350	145	168	324	397	675	63	125
150	6"	50	32	50	43	50	50	791290-3140	820	410	200	168	349	441	719	75	137
200	8"	29	11	40	16	50	20	791290-3150	820	410	200	226	402	494	830	75	232
200	8"	50	30	50	39	50	49	791290-3250	820	410	200	226	402	494	830	75	232
200	8"	50	50	50	50	50	50	791390-4250	1110	555	260	226	430	562	898	100	269
250	10"	16	-	23	7	30	9	791290-3160	820	410	200	264	456	548	922	75	342
250	10"	44	15	50	21	50	27	791290-3260	820	410	200	264	456	548	922	75	342
250	10"	50	40	50	50	50	50	791390-4260	1110	555	260	264	484	616	990	100	379
250	10"	50	50	50	50	Max air supply 5 bar		791390-4560	1250	695	395	264	484	616	990	100	423
300	12"	50	25	50	33	50	42	791390-4270	1110	555	260	311	540	672	1093	100	490
300	12"	50	50	50	50	Max air supply 5 bar		791390-4570	1250	695	395	311	540	672	1093	100	534
300	12"	50	50	50	50	50	50	791390-5170	1600	800	395	311	594	742	1163	150	644
350	14"	10	-	15	5	20	8	791390-4180	1110	555	260	344	634	766	1220	100	717
350	14"	31	14	41	20	50	26	791390-4280	1110	555	260	344	634	766	1220	100	717
350	14"	50	32	50	42	Max air supply 5 bar		791390-4580	1250	695	395	344	634	766	1220	100	761
350	14"	50	36	50	47	50	50	791390-5180	1600	800	395	344	688	836	1290	150	871
350	14"	50	50	50	50	50	50	791390-5280	1600	800	395	344	688	836	1290	150	871
400	16"	44	21	50	28	50	35	791390-5100	1600	800	395	384	749	897	1391	150	1082
400	16"	50	50	50	50	50	50	791390-5200	1600	800	395	384	749	897	1391	150	1082
450	18"	*	11	*	15	*	19	791390-5100	1600	800	395	414	724	872	1396	150	1299
450	18"	*	28	*	36	*	45	791390-5200	1600	800	395	414	724	872	1396	150	1299
500	20"	*	7	*	9	*	12	791390-5100	1600	800	395	468	778	926	1504	150	1710
500	20"	*	18	*	24	*	29	791390-5200	1600	800	395	468	778	926	1504	150	1710
600	24"	*	*	*	*	*	*	*	*	*	*	*	*	*	*	*	*
700	28"	*	*	*	*	*	*	*	*	*	*	*	*	*	*	*	*
800	32"	*	*	*	*	*	*	*	*	*	*	*	*	*	*	*	*

<sup>1</sup> Applies to average weight within the pressure classes in the tables

The above stated dP apply for clean media type water 20°C.

<sup>2</sup> Including all direct mounted Flowserve positioners (NAF 37-series, NAF-LinkIT, PMV P5/EP5, PMV D3, PMV D20, Logix 520MD+)

For other media contact Flowserve NAF, see also page 8.

\* Contact Flowserve NAF representative

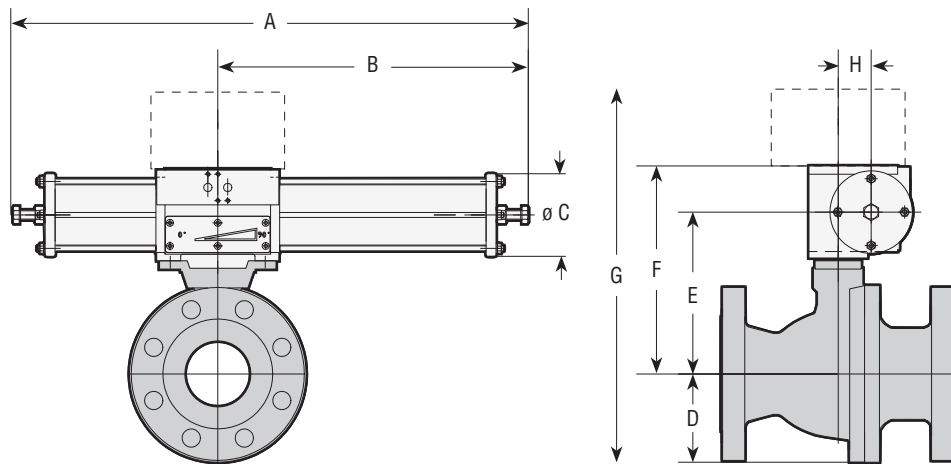

NAF791292/791392

**Table 7a: NAF Trunnball DL valves with NAF Turnex pneumatic actuator (spring to close) - PN10, PN16 and ANSI Class 150**

DN	Size	Max. dP bar at supply of						NAF No.	Dimensions, mm								Weight kg <sup>1</sup>
		4 bar		5 bar		6 bar			A	B	C	D	E	F	G <sup>2</sup>	H	
		R-PTFE	Alloy 6	R-PTFE	Alloy 6	R-PTFE	Alloy 6										
150	6"	20	6	20	9	20	9	791292-2240	890	540	145	168	324	397	675	63	125
150	6"	20	20	20	20	20	20	791292-3240	1050	640	200	168	349	441	719	75	143
200	8"	20	12	20	17	20	17	791292-3250	1050	640	200	213	402	494	817	75	218
200	8"	20	20	20	20	20	20	791392-4250	1520	965	260	213	430	562	885	100	275
250	10"	17	-	20	8	20	8	791292-3250	1050	640	200	264	456	548	922	75	312
250	10"	20	18	20	20	20	20	791392-4250	1520	965	260	264	484	616	990	100	369
250	10"	20	20	20	20	20	20	791392-4550	1665	965	395	264	484	616	990	100	414
300	12"	20	10	20	14	20	14	791392-4270	1520	965	260	303	540	672	1085	100	480
300	12"	20	14	20	14	20	14	791392-4570	1665	965	395	303	540	672	1085	100	525
300	12"	20	20	20	20	20	20	791392-5270	2210	1370	395	303	594	742	1155	150	865
350	14"	11	-	17	6	17	6	791392-4280	1520	965	260	344	634	766	1220	100	646
350	14"	17	6	17	6	17	6	791392-4580	1665	965	395	344	634	766	1220	100	691
350	14"	20	20	20	20	20	20	791392-5280	2210	1370	395	344	688	836	1290	150	1031
400	16"	8	-	8	-	8	-	791392-4580	1665	965	395	384	695	827	1321	100	846
400	16"	20	20	20	20	20	20	791392-5280	2210	1370	395	384	749	897	1391	150	1186
450	18"	*	12	*	17	*	17	791392-5280	2210	1370	395	414	724	872	1396	150	1395
500	20"	*	7	*	11	*	11	791392-5280	2210	1370	395	468	778	926	1504	150	1765
600	24"	*	*	*	*	*	*	*	*	*	*	*	*	*	*	*	*
700	28"	*	*	*	*	*	*	*	*	*	*	*	*	*	*	*	*
800	32"	*	*	*	*	*	*	*	*	*	*	*	*	*	*	*	*

<sup>1</sup> Applies to average weight within the pressure classes in the tables

<sup>2</sup> Including all direct mounted Flowserve positioners (NAF 37-series, NAF-LinkIT, PMV P5/EP5, PMV D3, PMV D20, Logix 520MD+)

\* Contact Flowserve NAF representative

The above stated dP apply for clean media type water 20°C.

For other media contact Flowserve NAF, see also page 8.

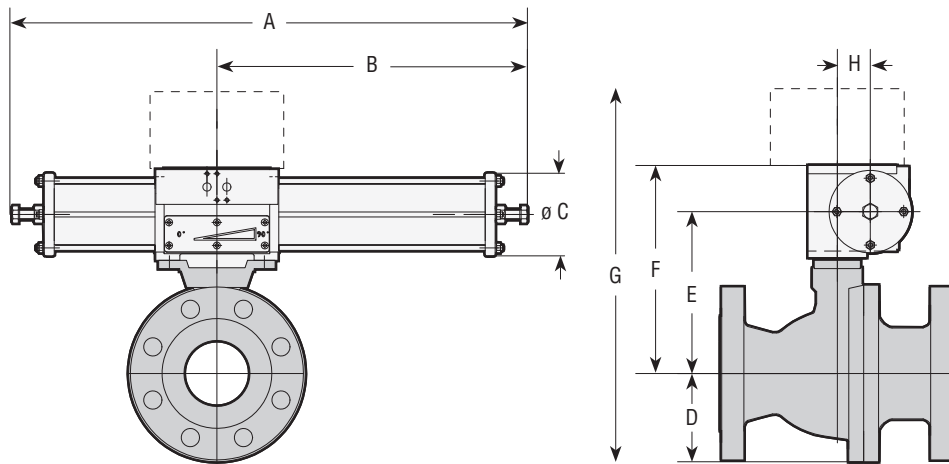

NAF791292/791392

**Table 7b: NAF Trunnball DL valves with NAF Turnex pneumatic actuator (spring to close) - PN25, PN40 and ANSI Class 300**

DN	Size	Max dP bar at supply of						NAF No.	Dimensions, mm								Weight kg <sup>1</sup>
		4 bar		5 bar		6 bar			A	B	C	D	E	F	G <sup>2</sup>	H	
		R-PTFE	Alloy 6	R-PTFE	Alloy 6	R-PTFE	Alloy 6										
150	6"	30	6	40	9	40	9	791292-2240	890	540	145	168	324	397	675	63	133
150	6"	50	35	50	46	50	46	791292-3240	1050	640	200	168	349	441	719	75	151
150	6"	50	50	50	50	50	50	791392-4240	1520	965	260	168	377	509	787	100	208
200	8"	32	12	43	17	43	17	791292-3250	1050	640	200	226	402	494	830	75	246
200	8"	50	33	50	45	50	45	791392-4250	1520	965	260	226	430	562	898	100	303
200	8"	50	45	50	45	50	45	791392-4550	1665	965	395	226	430	562	898	100	348
250	10"	50	18	50	24	50	24	791392-4260	1520	965	260	264	484	616	990	100	413
250	10"	50	24	50	24	50	24	791392-4560	1665	965	395	264	484	616	990	100	458
250	10"	50	50	50	50	50	50	791392-5260	2210	1370	395	264	538	686	1060	150	798
300	12"	24	10	33	14	33	14	791392-4270	1520	965	260	311	540	672	1093	100	524
300	12"	33	14	33	14	33	14	791392-4570	1665	965	395	311	540	672	1093	100	569
300	12"	50	50	50	50	50	50	791392-5270	2210	1370	395	311	594	742	1163	150	909
350	14"	11	-	17	6	17	6	791392-4280	1520	965	260	344	634	766	1220	100	751
350	14"	17	6	17	6	17	6	791392-4580	1665	965	395	344	634	766	1220	100	796
350	14"	50	38	50	50	50	50	791392-5280	2210	1370	395	344	688	836	1290	150	1136
400	16"	47	22	50	31	50	31	791392-5200	2210	1370	395	384	749	897	1391	150	1347
450	18"	*	12	*	17	*	17	791392-5200	2210	1370	395	414	724	872	1396	150	1564
500	20"	*	7	*	11	*	11	791392-5200	2210	1370	395	468	778	926	1504	150	1975
600	24"	*	*	*	*	*	*	*	*	*	*	*	*	*	*	*	*
700	28"	*	*	*	*	*	*	*	*	*	*	*	*	*	*	*	*
800	32"	*	*	*	*	*	*	*	*	*	*	*	*	*	*	*	*

<sup>1</sup> Applies to average weight within the pressure classes in the tables

<sup>2</sup> Including all direct mounted Flowserve positioners (NAF 37-series, NAF-LinkIT, PMV P5/EP5, PMV D3, PMV D20, Logix 520MD+)

\* Contact Flowserve NAF representative

The above stated dP apply for clean media type water 20°C.

For other media contact Flowserve NAF, see also page 8.

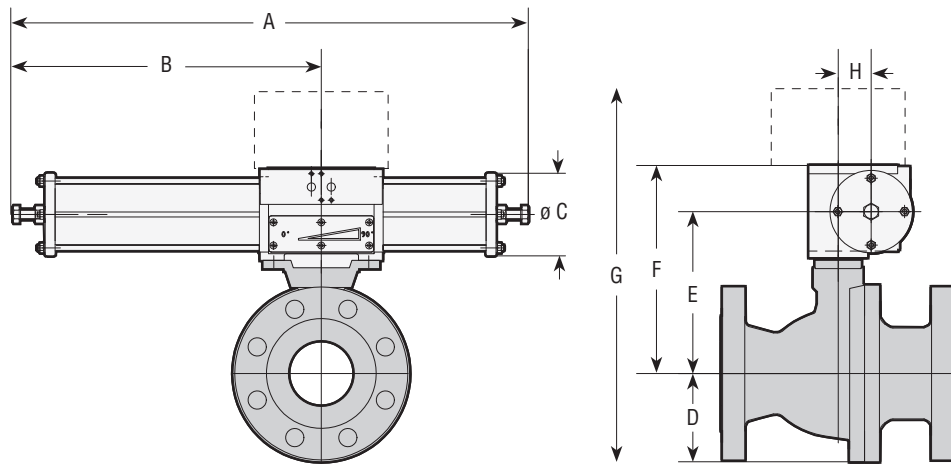

NAF791294/791394

**Table 8a: NAF Trunnball DL valves with NAF Turnex pneumatic actuator (spring to open) - PN10, PN16 and ANSI Class 150**

DN	Size	Max dP bar at supply of						NAF No.	Dimensions, mm								Weight kg <sup>1</sup>
		4 bar		5 bar		6 bar			A	B	C	D	E	F	G <sup>2</sup>	H	
		R-PTFE	Alloy 6	R-PTFE	Alloy 6	R-PTFE	Alloy 6										
150	6"	20	14	20	20	20	20	791294-3240	1050	640	200	168	349	441	719	75	143
150	6"	20	20	20	20	20	20	791394-4240	1520	965	260	168	377	509	787	100	200
200	8"	11	-	20	16	20	20	791294-3250	1050	640	200	213	402	494	817	75	218
200	8"	20	20	20	20	20	20	791294-4250X196 <sup>3</sup>	1520	965	260	213	430	562	885	100	303
250	10"	-	-	20	7	20	11	791294-3250	1050	640	200	264	456	548	922	75	312
250	10"	20	18	20	18	20	18	791394-4250X196 <sup>3</sup>	1520	965	260	264	484	616	990	100	369
250	10"	16	-	20	20	20	20	791394-4250	1520	965	260	264	484	616	990	100	369
250	10"	20	20	20	20	20	20	791394-4550	1665	965	395	264	484	616	990	100	414
300	12"	20	10	20	10	20	10	791394-4270X196 <sup>3</sup>	1520	965	260	303	540	672	1085	100	480
300	12"	5	-	20	12	20	20	791394-4270	1520	965	260	303	540	672	1085	100	480
300	12"	20	20	20	20	20	20	791394-4570	1665	965	395	303	540	672	1085	100	525
350	14"	-	-	14	5	20	10	791394-4280	1520	965	260	344	634	766	1220	100	646
350	14"	20	10	20	10	20	10	791394-4580	1665	965	395	344	634	766	1220	100	691
350	14"	20	20	20	20	20	20	791394-5280X383 <sup>3</sup>	2210	1370	395	344	688	836	1290	150	1031
400	16"	20	20	20	20	20	20	791394-5280X383 <sup>3</sup>	2210	1370	395	384	749	897	1391	150	1186
400	16"	17	6	20	20	20	20	791394-5280	2210	1370	395	384	749	897	1391	150	1186
450	18"	*	11	*	16	*	16	791394-5280X383 <sup>3</sup>	2210	1370	395	414	724	872	1396	150	1395
450	18"	*	-	*	15	*	22	791394-5280	2210	1370	395	414	724	872	1396	150	1395
500	20"	*	7	*	10	*	10	791394-5280X383 <sup>3</sup>	2210	1370	395	468	778	926	1504	150	1765
500	20"	*	-	*	9	*	14	791394-5280	2210	1370	395	468	778	926	1504	150	1765
600	24"	*	*	*	*	*	*	*	*	*	*	*	*	*	*	*	*
700	28"	*	*	*	*	*	*	*	*	*	*	*	*	*	*	*	*
800	32"	*	*	*	*	*	*	*	*	*	*	*	*	*	*	*	*

<sup>1</sup> Applies to average weight within the pressure classes in the tables

<sup>2</sup> Including all direct mounted Flowserve positioners (NAF 37-series, NAF-LinkIT, PMV P5/EP5, PMV D3, PMV D20, Logix 520MD+)

<sup>3</sup> Only used for low supply pressure

\* Contact Flowserve NAF representative

The above stated dP apply for clean media type water 20°C.

For other media contact Flowserve NAF, see also page 8.



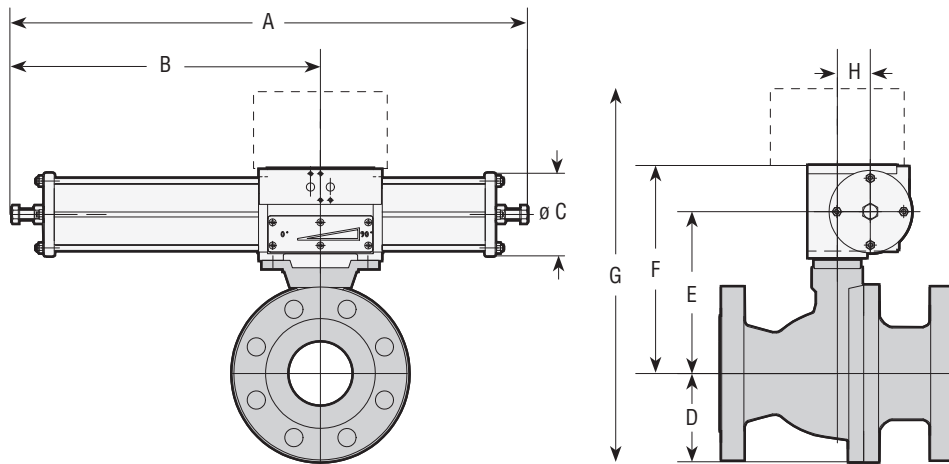

NAF791294/791394

**Table 8b: NAF Trunnball DL valves with NAF Turnex pneumatic actuator (spring to open) - PN25, PN40 and ANSI Class 300**

DN	Size	Max dP bar at supply of						NAF No.	Dimensions, mm								Weight kg <sup>1</sup>
		4 bar		5 bar		6 bar			A	B	C	D	E	F	G <sup>2</sup>	H	
		R-PTFE	Alloy 6	R-PTFE	Alloy 6	R-PTFE	Alloy 6										
150	6"	50	14	50	43	50	50	791294-3240	1050	640	200	168	349	441	719	75	151
150	6"	50	34	50	50	50	50	791394-4240	1520	965	260	168	377	509	787	100	208
200	8"	11	-	40	16	50	23	791294-3250	1050	640	200	226	402	494	830	75	246
200	8"	50	35	50	35	50	35	791294-4250X196 <sup>3</sup>	1520	965	260	226	430	562	898	100	303
200	8"	31	11	50	40	50	50	791294-4250	1520	965	260	226	430	562	898	100	303
200	8"	50	50	50	50	50	50	791294-4550	1665	965	395	226	430	562	898	100	348
250	10"	50	18	50	18	50	18	791394-4260X196 <sup>3</sup>	1520	965	260	264	484	616	990	100	413
250	10"	16	-	50	21	50	32	791394-4260	1520	965	260	264	484	616	990	100	413
250	10"	50	32	50	32	50	32	791394-4560	1665	965	395	264	484	616	990	100	458
250	10"	50	50	50	50	50	50	791394-5260X383 <sup>3</sup>	2210	1370	395	264	538	686	1060	150	798
300	12"	25	10	25	10	25	10	791394-4270X196 <sup>3</sup>	1520	965	260	311	540	672	1093	100	524
300	12"	5	-	29	12	44	20	791394-4270	1520	965	260	311	540	672	1093	100	524
300	12"	44	20	44	20	44	20	791394-4570	1665	965	395	311	540	672	1093	100	569
300	12"	50	50	50	50	50	50	791394-5270X383 <sup>3</sup>	2210	1370	395	311	594	742	1163	150	909
350	14"	-	-	14	5	24	10	791394-4280	1520	965	260	344	634	766	1220	100	751
350	14"	24	10	24	10	24	10	791394-4580	1665	965	395	344	634	766	1220	100	796
350	14"	50	35	50	49	50	49	791394-5280X383 <sup>3</sup>	2210	1370	395	344	688	836	1290	150	1136
400	16"	43	20	50	30	50	30	791394-5200X383 <sup>3</sup>	2210	1370	395	384	749	897	1391	150	1347
400	16"	17	6	50	27	50	39	791394-5200	2210	1370	395	384	749	897	1391	150	1347
450	18"	*	11	*	16	*	16	791394-5200X383 <sup>3</sup>	2210	1370	395	414	724	872	1396	150	1564
450	18"	*	-	*	15	*	22	791394-5200	2210	1370	395	414	724	872	1396	150	1564
500	20"	*	7	*	10	*	10	791394-5200X383 <sup>3</sup>	2210	1370	395	468	778	926	1504	150	1975
500	20"	*	-	*	9	*	14	791394-5200	2210	1370	395	468	778	926	1504	150	1975
600	24"	*	*	*	*	*	*	*	*	*	*	*	*	*	*	*	*
700	28"	*	*	*	*	*	*	*	*	*	*	*	*	*	*	*	*
800	32"	*	*	*	*	*	*	*	*	*	*	*	*	*	*	*	*

<sup>1</sup> Applies to average weight within the pressure classes in the tables

<sup>2</sup> Including all direct mounted Flowserve positioners (NAF 37-series, NAF-LinkIT, PMV P5/EP5, PMV D3, PMV D20, Logix 520MD+)

<sup>3</sup> Only used for low supply pressure

\* Contact Flowserve NAF representative

The above stated dP apply for clean media type water 20°C.

For other media contact Flowserve NAF, see also page 8.

## ***Actuators***

The pneumatic actuators NAF Turnex can be directly mounted to the NAF Trunnball DL without any couplings or brackets. Together with the direct mounting capabilities of all NAF positioners and several Flowserve positioners (PMV P5/EP5, PMV D3/D20 and Logix 520 MD Plus), this provides a high performance, vibration resistant and compact valve package suitable for precision control.

Please see data sheet for further information on the NAF Turnex actuator capabilities and all other available accessories.

## Product Code for NAF Trunnball DL

Example:

Code **89** **8** **4** **K** **F** - **0012** - **BAB** **A** **E** **A - C**  
 1 2 3 4 5 6 7 8 9 10 11

1. **Valve type**  
**89** NAF Trunnball DL  
**Z-89** NAF Trunnball DL with Z-trim option<sup>1</sup>
2. **Material**  
**6** WCB (~EN 1.0619)  
**8** CF8M (~EN 1.4408)  
 For other materials, please see <sup>2</sup>
3. **Pressure rating**  
**2** PN 10 (DN 200–800)<sup>3</sup>  
**3** PN 16 (DN 150–800)  
**4** ANSI Class 150 (Size 6”–32”)  
**5** PN 25 (DN 200–800)<sup>3</sup>  
**6** PN 40 (DN 150–800)  
**7** ANSI Class 300 (Size 6”–32”)
4. **Stem bearing**  
**K** R-PTFE, Carbon reinforced
5. **Body type**  
**F** Flanged
6. **Size**  

PN ratings	DN	ANSI ratings	Size
0150	150	0006	6”
0200	200	0008	8”
0250	250	0010	10”
0300	300	0012	12”
0350	350	0014	14”
0400	400	0016	16”
0450	450	0018	18”
0500	500	0020	20”
0600	600	0024	24”
0700	700	0028	28”
0800	800	0032	32”
7. **Seat, ball and ball overlay**  

	Seat	Ball	Overlay
<b>AAA</b>	R-PTFE, carbon reinforced	CF8M / 316 (~EN 1.4408)	-
<b>BAB</b>	Alloy 6 overlay/SS	CF8M / 316 (~EN 1.4408)	Hard Chrome <sup>5</sup>
<b>BAC</b>	Alloy 6 overlay/SS	CF8M / 316 (~EN 1.4408)	Electroless Nickel
<b>BAD</b>	Alloy 6 overlay/SS	CF8M / 316 (~EN 1.4408)	Alloy 6

  
 For other materials for the ball, please see <sup>2</sup>

8. **Seat seal**  
**A** PTFE, max t=250 °C
9. **Stem seal**  
**E** Spring loaded R-PTFE V-rings, carbon reinforced  
**F** Spring loaded graphite + R-PTFE V-rings, carbon reinforced
10. **Stem material**  
**A** Duplex EN 1.4460 (~AISI 329)
11. **Options<sup>4</sup>**  
**C** Ball with straight cylindrical flow path, solid ball DN300–400 / 12”–16”  
**D** Degreased for oxygen service  
**XA** ATEX certified

Versions marked in bold text are the standard versions with shortest leadtime.

<sup>1</sup> Sizes DN150–500 / 6”–20”

<sup>2</sup> For material CF8, CF3M, CG3M, CG8M, Duplex EN 1.4470, CW-12MW, 904L, M35-01, CK3MCuN, titanium B367 Grade C2, 904L etc, please contact Flowserve NAF

<sup>3</sup> Size 150 has the same dimensions in PN 10 and PN 16. Choose PN 16 for this size.  
 Size 150 has the same dimensions in PN 25 and PN 40. Choose PN 40 for this size.

<sup>4</sup> If a combination of several options is specified, please add them to a multi-sign code in alphabetic order

<sup>5</sup> For DN 600-800/ 24” - 32” the overlay is chromium carbide



**NAF AB**  
SE-581 87 Linköping  
Sweden  
Telephone: +46 13 31 61 00  
Fax: +46 13 13 60 54  
E-mail: [salesnaf@flowserve.com](mailto:salesnaf@flowserve.com)  
Website: [www.flowserve.com](http://www.flowserve.com)  
[www.naf.se](http://www.naf.se)

NFENTB4168-01-A4 December 2014

***To find your local Flowserve representative***  
or for more information about Flowserve Corporation,  
visit [www.flowserve.com](http://www.flowserve.com) or call USA 1 800 225 6989

Flowserve Corporation has established industry leadership in the design and manufacture of its products. When properly selected, this Flowserve product is designed to perform its intended function safely during its useful life. However, the purchaser or user of Flowserve products should be aware that Flowserve products might be used in numerous applications under a wide variety of industrial service conditions. Although Flowserve can (and often does) provide general guidelines, it cannot provide specific data and warnings for all possible applications. The purchaser/user must therefore assume the ultimate responsibility for the proper sizing and selection, installation, operation, and maintenance of Flowserve products. The purchaser/user should read and understand the Installation Operation Maintenance (IOM) instructions included with the product, and train its employees and contractors in the safe use of Flowserve products in connection with the specific application.

While the information and specifications contained in this literature are believed to be accurate, they are supplied for informative purposes only and should not be considered certified or as a guarantee of satisfactory results by reliance thereon. Nothing contained herein is to be construed as a warranty or guarantee, express or implied, regarding any matter with respect to this product. Because Flowserve is continually improving and upgrading its product design, the specifications, dimensions and information contained herein are subject to change without notice. Should any question arise concerning these provisions, the purchaser/user should contact Flowserve Corporation at any one of its worldwide operations or offices.

© 2014 Flowserve Corporation, Irving, Texas, USA. Flowserve is a registered trademark of Flowserve Corporation.